

Standard Series BSL12-100 12V100Ah

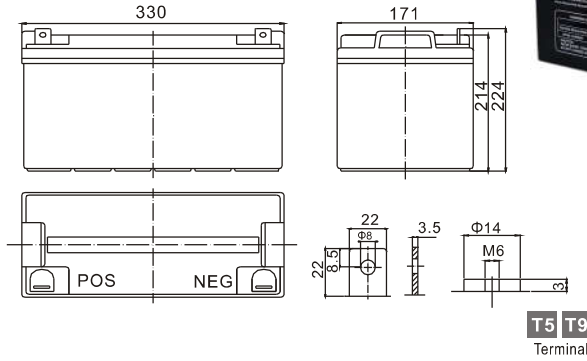

Dimension(mm)



Specification

Nominal Voltage	12 V	
Capacity(10HR, 25°C)	100 Ah	
Dimension	Length	330mm (13.0inch)
	Width	171mm (6.7inch)
	Height	214mm (8.4inch)
	Total Height(T5/T9)	224mm (8.8inch)/220mm (8.7inch)
Approx. Weight	30.5kg (67.1lbs)	

The Relationship for Open Circuit Voltage and Residual Capacity (25°C)

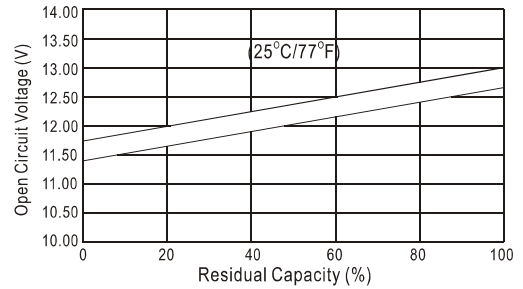

Characteristics

Capacity 20°C (68°F) To 1.70V/Cell	20 hour rate	107Ah
	10 hour rate	100Ah
	5 hour rate	91Ah
	1 hour rate	62.4Ah
	15 min rate	42Ah
Internal resistance(Fully charged, 25°C)	Approx. 4.5mΩ	
Capacity affected by temperature (10HR)	40°C	102%
	25°C	100%
	0°C	85%
	-15°C	65%
Self-discharge (25°C)	3 month	Remaining Capacity: 91%
	6 month	Remaining Capacity: 82%
	12 month	Remaining Capacity: 65%
Nominal operating temperature	25°C ±3°C (77°F ±5°F)	
Operating temperature range	-15°C ~ -50°C (5°F ~ 122°F)	
Float charging voltage(25°C)	13.50 to 13.80V	
Cyclic charging voltage(25°C)	14.50 to 14.90V	
Maximum charging current	30A	
Terminal material	Copper	
Maximum discharge current	800A(5 Sec.)	

Charging Characteristics(25°C)

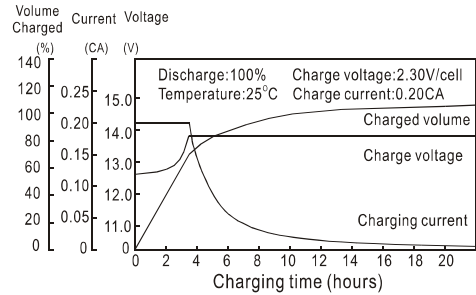

Cycle Life(25°C)

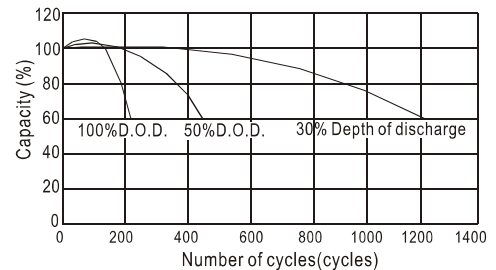

Constant Current Discharge Characteristics (A, 25°C)

F.V/TIME	5min	10min	15min	30min	60min	3h	5h	10h	20h
9.60V	320	220	175	108	65.0	26.4	18.5	10.3	5.35
10.2V	304	209	168	104	62.4	26.0	18.2	10.2	5.35
10.8V	286	196	160	98.8	59.3	25.5	17.8	10.0	5.30

Constant Power Discharge Characteristics (Watt, 25°C)

	5min	10min	15min	30min	60min	3h	5h	10h	20h
	3360	2376	1922	1212	741	310	219	123	64.2
	3192	2257	1845	1167	711	306	215	122	64.2
	3003	2117	1757	1109	676	300	210	119	63.6