

# Standard Series BS6-12 6V12Ah

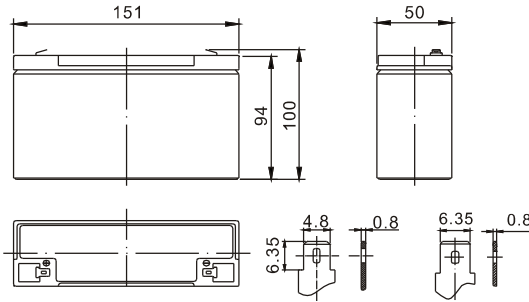

## Dimension(mm)



T1 T2  
Terminal



## Specification

Nominal Voltage		6 V
Capacity(20HR, 25 °C)		12Ah
Dimension	Length	151mm (5.94inch)
	Width	50mm (1.97inch)
	Height	94mm (3.70inch)
	Total Height(T1/T2)	100mm (3.94inch)
Approx. Weight		1.82kg (4.00lbs)

## Characteristics

Capacity 20 (68H ) To 1.70V/Cell	20 hour rate	12Ah
	10 hour rate	11.3Ah
	5 hour rate	10.25Ah
	1 hour rate	7.49Ah
	15 min rate	5.83Ah
Internal resistance(Fully charged, 25 °C)		Approx. 11m
Capacity affected by temperature (20HR)	40	102%
	25	100%
	0	85%
	-15	65%
Self-discharge (25 °C)	3 month	Remaining Capacity: 91%
	6 month	Remaining Capacity: 82%
	12 month	Remaining Capacity: 65%
Nominal operating temperature		25 3 (77H 5H )
Operating temperature range		-15 ~50 (5H ~122H )
Float charging voltage(25 °C)		6.80 to 6.90V
Cyclic charging voltage(25 °C)		7.25 to 7.45V
Maximum charging current		3.6A
Terminal material		Copper
Maximum discharge current		180A(5 Sec.)

## The Relationship for Open Circuit Voltage and Residual Capacity (25°C)

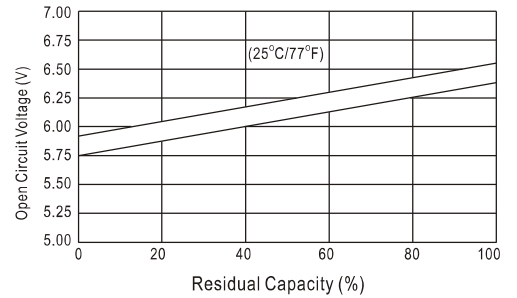

## Charging Characteristics(25°C)

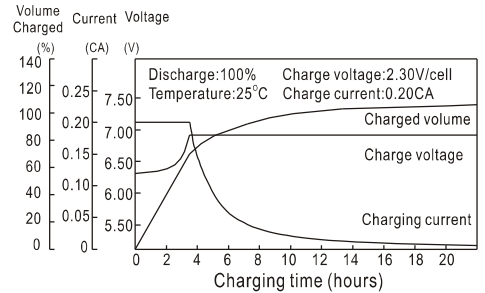

## Cycle Life(25°C)

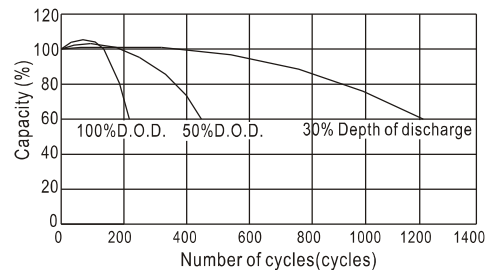

## Constant Current Discharge Characteristics (A, 25°C)

F.V/TIME	5min	10min	15min	30min	60min	3h	5h	10h	20h
4.80V	46.0	31.0	24.5	13.5	7.80	3.18	2.09	1.14	0.61
5.10V	43.7	29.5	23.3	13.0	7.49	3.12	2.05	1.13	0.61
5.40V	41.0	27.7	21.9	12.3	7.11	3.03	2.00	1.10	0.59

## Constant Power Discharge Characteristics (Watt, 25°C)

	5min	10min	15min	30min	60min	3h	5h	10h	20h
	257	175	140	77.3	45.2	18.9	12.5	6.84	3.66
	244	166	133	74.5	43.4	18.5	12.2	6.78	3.66
	229	156	125	70.5	41.1	18.0	11.9	6.60	3.54