

Standard Series BS12-7 SEC 12V7.0Ah

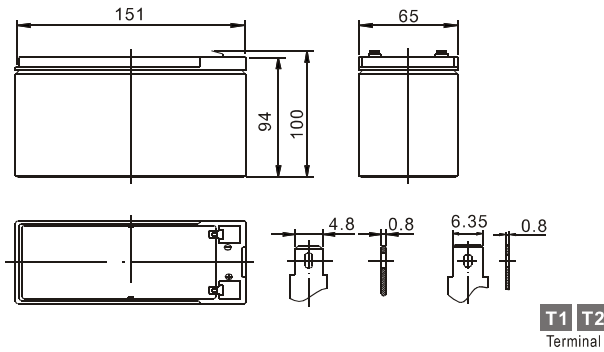

Dimension



Specification

Nominal Voltage		12 V
Capacity(20HR, 25°C)		7.0 Ah
Dimension	Length	151mm (5.94inch)
	Width	65mm (2.56inch)
	Height	94mm (3.70inch)
	Total Height	100mm (3.94inch)
Approx. Weight		2.10kg (4.63lbs)

Characteristics

Capacity 20°C (68°F) To 1.70V/Cell	20 hour rate	7Ah
	10 hour rate	6Ah
	5 hour rate	5.55Ah
	1 hour rate	4.06Ah
	15 min rate	3Ah
Internal resistance(Fully charged, 25°C)		Approx. 28mΩ
Capacity affected by temperature (20HR)	40°C	102%
	25°C	100%
	0°C	85%
	-15°C	65%
Self-discharge (25°C)	3 month	Remaining Capacity: 91%
	6 month	Remaining Capacity: 82%
	12 month	Remaining Capacity: 65%
Nominal operating temperature		25°C±3°C(77°F±5°F)
Operating temperature range		-15°C~50°C(5°F~122°F)
Float charging voltage(25°C)		13.60 to 13.80V
Cyclic charging voltage(25°C)		14.50 to 14.90V
Maximum charging current		1.95A
Terminal material		Copper
Maximum discharge current		97.5A(5 Sec.)

The Relationship for Open Circuit Voltage and Residual Capacity (25°C)

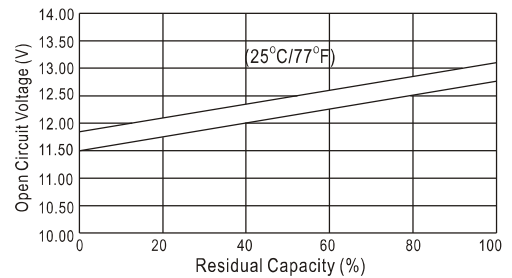

Charging Characteristics(25°C)

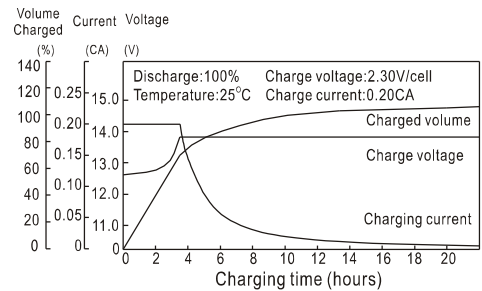

Cycle Life(25°C)

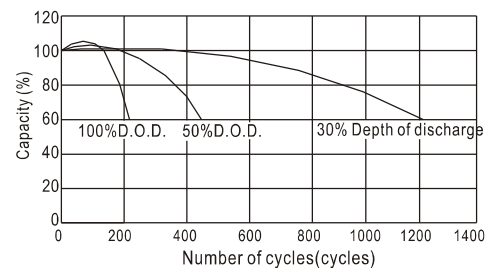

Constant Current Discharge Characteristics (A, 25°C)

F.V/TIME	5min	10min	15min	30min	60min	3h	5h	10h	20h
9.60V	24.7	15.6	12.4	7.15	4.23	1.65	1.12	0.61	0.330
10.2V	23.5	14.8	11.9	6.86	4.06	1.63	1.11	0.60	0.327
10.8V	22.1	13.9	11.3	6.52	3.85	1.59	1.08	0.60	0.325

Constant Power Discharge Characteristics (Watt, 25°C)

	5min	10min	15min	30min	60min	3h	5h	10h	20h
276	176	141	81.9	48.9	19.6	13.4	7.28	3.96	
262	167	135	78.7	47.0	19.3	13.2	7.22	3.92	
246	157	128	74.7	44.6	18.9	12.9	7.22	3.90	